

TC1520

RS-422, 2/4-wire RS-485 FIBER OPTIC MODEM User's Manual

MODEL: _____

S/N: _____

DATE: _____

Notice!

Although every effort has been made to insure that this manual is current and accurate as of date of publication, no guarantee is given or implied that this document is error free or accurate with regard to any specification. TC Communications, Inc. reserves the right to change or modify the contents of this manual at any time without prior notification.

© COPYRIGHT 1992-2004. ALL RIGHTS RESERVED.



TC Communications, Inc. 17575 Cartwright Road - Irvine, CA 92614

Tel: (949) 852-1972 Fax: (949) 852-1948 Web Site: www.tccomm.com Email: info@tccomm.com

Table Of Contents

Chapter 1 - Overview	3
Description	3
RS-422 and 4-wire RS-485 Connection	4
2-wire RS-485 Pin Connection	4
Switch Functions	5
Transmission Distances (typical)	5
Launch Power & Sensitivity	5
Power Supply	5
LED Functions	6
Theory of 2-Wire RS-485 Operation	7
Termination of RS-422 or 2-wire RS-485	8
Chapter 2 - Installation	9
Unpacking the Unit	9
Equipment Location	9
Installation Procedure Summary	9
Quick Installation example for 4-wire RS-485	10
Quick Installation example for 2-wire RS-485	11
Testing for the 2-wire RS-485 with RS-530 tester	12
Testing for the 2-wire RS-485 with RS-449 tester	13
Chapter 3 - Specifications	14
Chapter 4 - Appendix	15
Return Policy	15
Warranty	15

Chapter 1 - Overview

Description

The TC1520 Fiber Optic Modems interconnect a host controller with remote RTU (remote terminal unit) devices fitted with RS-422 and 4-wire or 2-wire RS-485 interfaces. Asynchronous data rates up to 500kbps are supported. The RS-422 interface is standard, 4-wire or 2-wire RS-485 interface is switch selectable. The TC1520 is equipped with four DIP switches and six LED indicators on the top of the cover to facilitate the installation and troubleshooting process.

The TC1520T is a high temperature option (-20°C to 70°C). Fiber optic connectors are ST; FC is optional. Electrical connectors are terminal blocks.

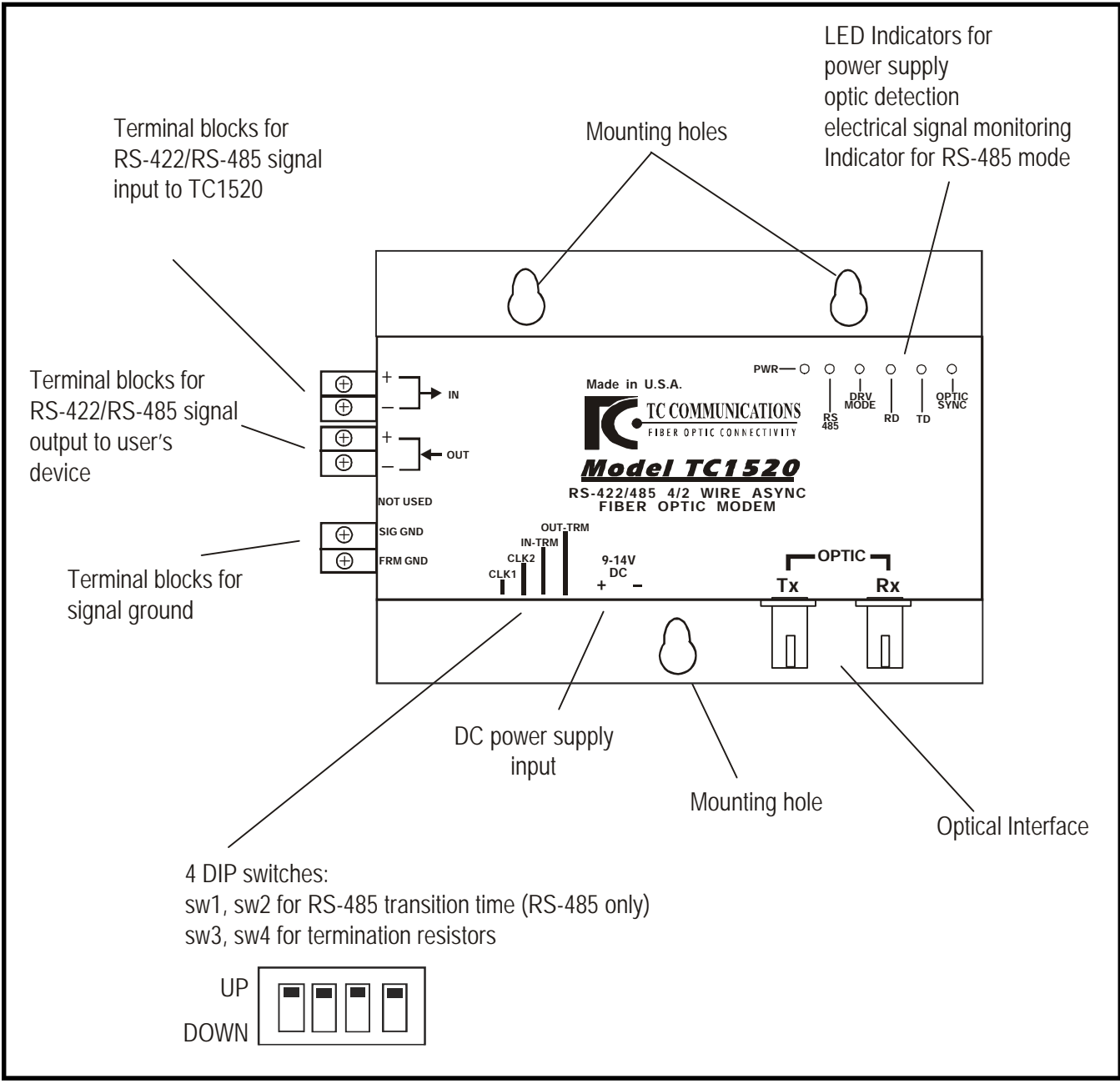

RS-422 and 4-wire RS-485 Connection

When both CLK and CLK2 switches are at the "UP" position, the TC1520 is setup for an RS-422 application.

When any or both of CLK and CLK2 is at the "DOWN" position, the TC1520 is setup for an RS-485 application. The CLK1 and CLK2 should be set according to actual data baud rate. (page 5)

The signal ground should connect to user's device's signal ground.

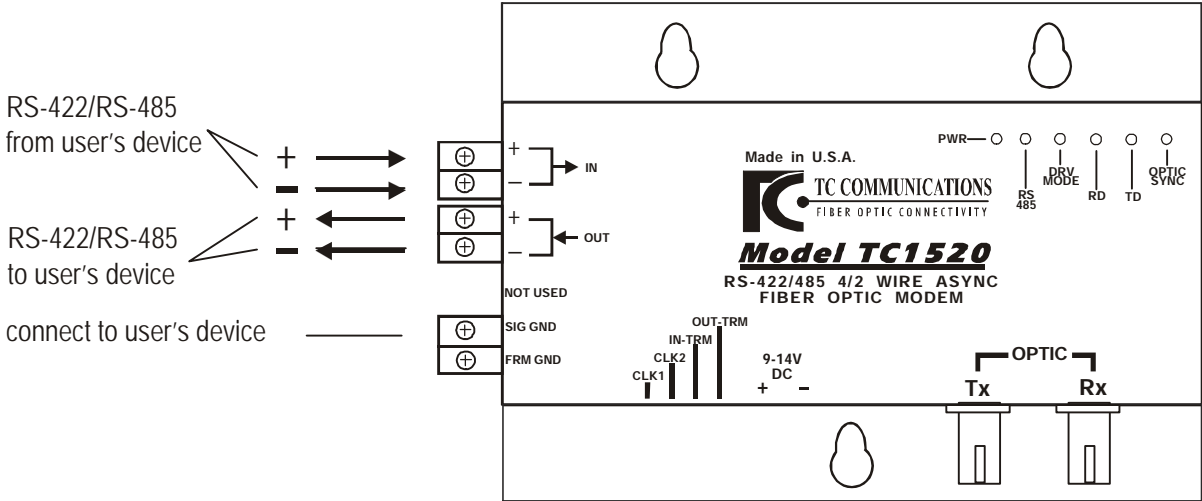

2-wire RS-485 Pin Connection

For 2-wire RS-485 application, only "IN" signals should be used. The signal ground should connect to user's device's signal ground.

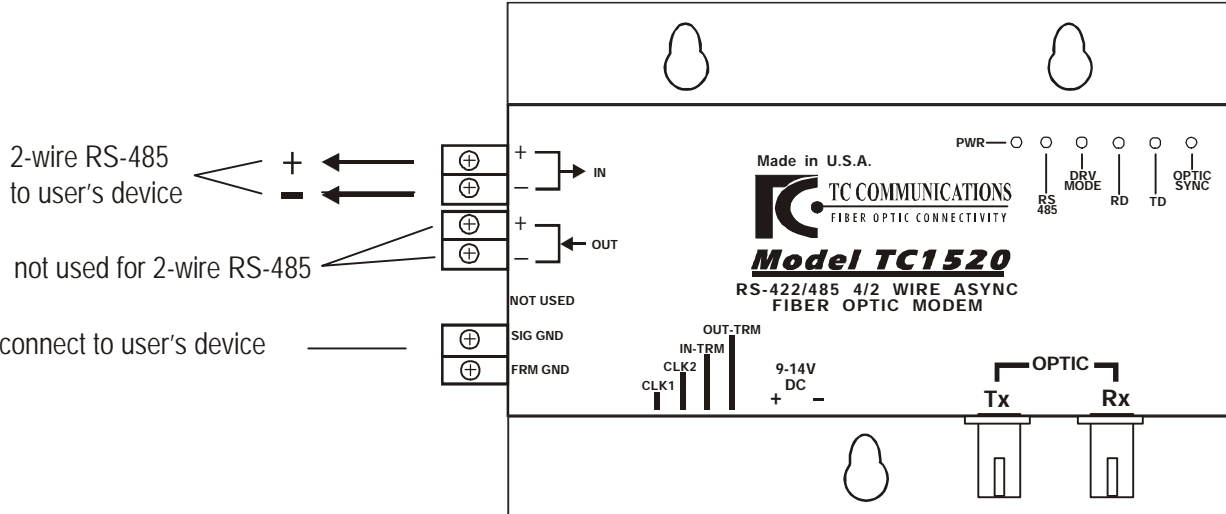

Switch Functions

CLK1, CLK2

two switches marked as “CLK1,” “CLK2” are for RS-485’s transition time setup. If both switches are at “up” position, then “IN” and “OUT” terminals are setup to RS-422’s applications. If both or any of “CLK1” and “CLK2” is set to “down” position the electrical interface is set to RS-485 applications.

IN-TRM, OUT-TRM - The other two switches marked as “IN-TRM” and “OUT-TRM” are used for termination resistors. “IN-TRM” is for input termination and “OUT-TRM” is for output termination.

CLK1	CLK2	
0	0	RS-422 only
1	0	4/2-wire RS-485 for baud rate > 9600bps
0	1	4/2-wire RS-485 for baud rate > 25 kbps
1	1	4/2-wire RS-485 for baud rate > 250 kbps

0 = UP
1 = DOWN

Transmission Distances (typical)

The TC1520 is compatible with all popular sizes and types of fiber. Transmission distances up to 3km* are typical over Multimode fiber at 850nm and 4km* at 1310nm. Distances to 35km* are typical over Single Mode fiber at 1310nm.

Launch Power & Sensitivity

Transmitter:	LED/ELED; typical Launch Power -	-20dBm* (850nm/1310nm MM, @62.5/125µm) -16dBm* (1310nm Single Mode, @9/125µm)
Receiver:	PIN Diode; typical Sensitivity -	-36dBm* (850nm/1310nm MM, @62.5/125µm) -36dBm* (1310nm Single Mode, @9/125µm)

**Launch power, sensitivity and distance are listed for reference only. These numbers may vary.*

Power Supply

Typically, a 9V to 14V DC power supply @200mA is adequate for the TC1520, optional 115 /230VAC with an external power cube. The power plug is a terminal block connector with positive & negative polarity indicated on the top panel of the unit.

LED Functions

There are six LED indicators to ease installation and troubleshooting. Users can monitor optic signal status, RS-422/RS-485 signal status at "IN" and "OUT" terminals, distinguish RS-422/RS-485 mode, or identify "drive" or "receive" mode at "OUT" terminals. The "TD" LED is the status on "IN" terminals, "RD" LED is the status on "OUT" terminals.

For RS-485 applications, drive mode and receive mode for "OUT" terminals is indicated by "DRV MODE" LED.

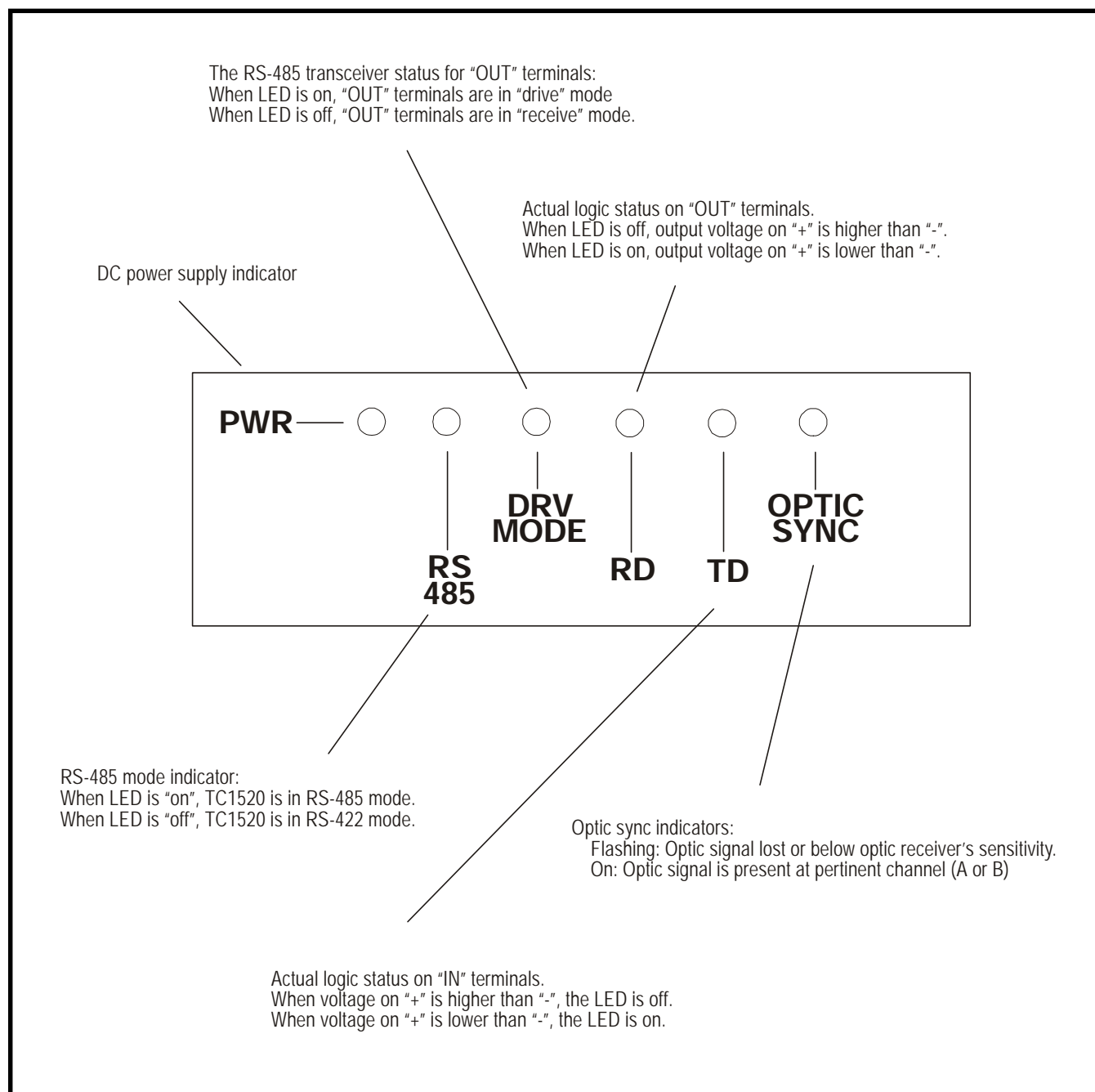

Theory of 2-Wire RS-485 Operation

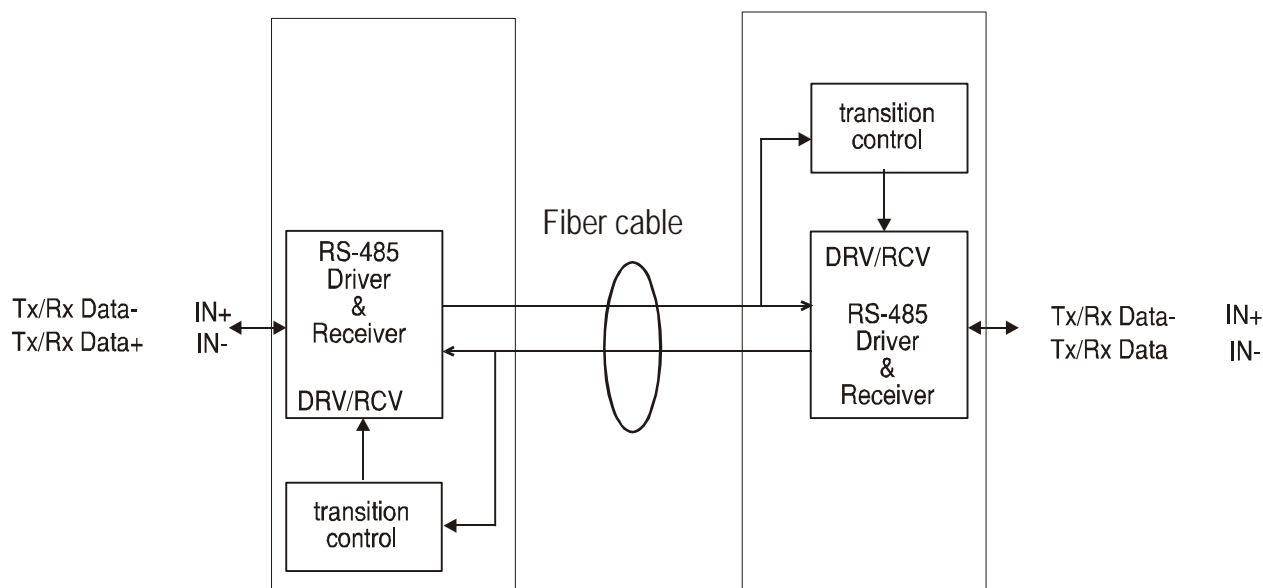

2-wire RS-485 is half-duplex operation, which means transmit and receive operations take turns; they do not operate concurrently. From the user's point of view, the channel is in receiving mode when no data is transmitted from the remote unit. The local RS-485 transceiver will change to transmitting mode (Tx mode) upon receiving the first bit of data from remote unit. The local RS-485 transceiver will stay in Tx mode until a predetermined period (set by front panel switch CLK1, CLK2) elapses after the last bit from the remote unit. The following table provides the setting of the front panel DIP switches which determine the elapsed period after the last bit of the data stream's received from remote unit. The listed baud rates is only for reference. The best result still comes from trial and error. For example, if you know the async data baud rate is 9600, then set CLK1 to "DOWN", CLK2 to "UP". You may also want to try the 25K and 250K settings for a 9600 baud rate as a test to make sure the best transition time.

Important thing to remember is to try the fastest transition time first (the default setting) which usually would work for most of the baud rate.

CLK1	CLK2	
0	0	RS-422 only
1	0	4/2-wire RS-485 for baud rate > 9600bps
0	1	4/2-wire RS-485 for baud rate > 25 kbps
1	1	4/2-wire RS-485 for baud rate > 250 kbps

0 = UP
1 = DOWN

Termination of RS-422 or 2-wire RS-485

A termination resistor is necessary for RS-422 or RS-485 applications. Without proper termination, the error rate of data transmission may be high. The termination resistor is a 120 ohm resistor located only at the beginning or end of the electrical bus as shown in the following diagram. TC1520 is equipped with two DIP switches, "IN-TRM" and "OUT-TRM", for input and output termination resistors. Their functions are depicted as following:

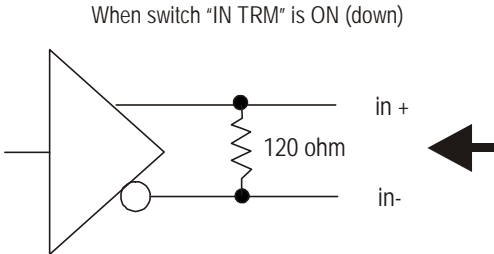
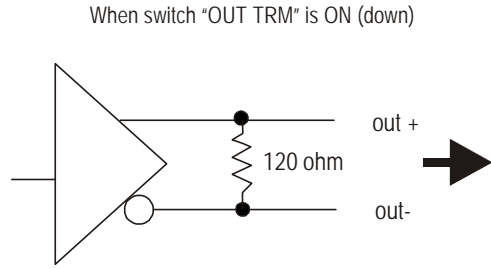
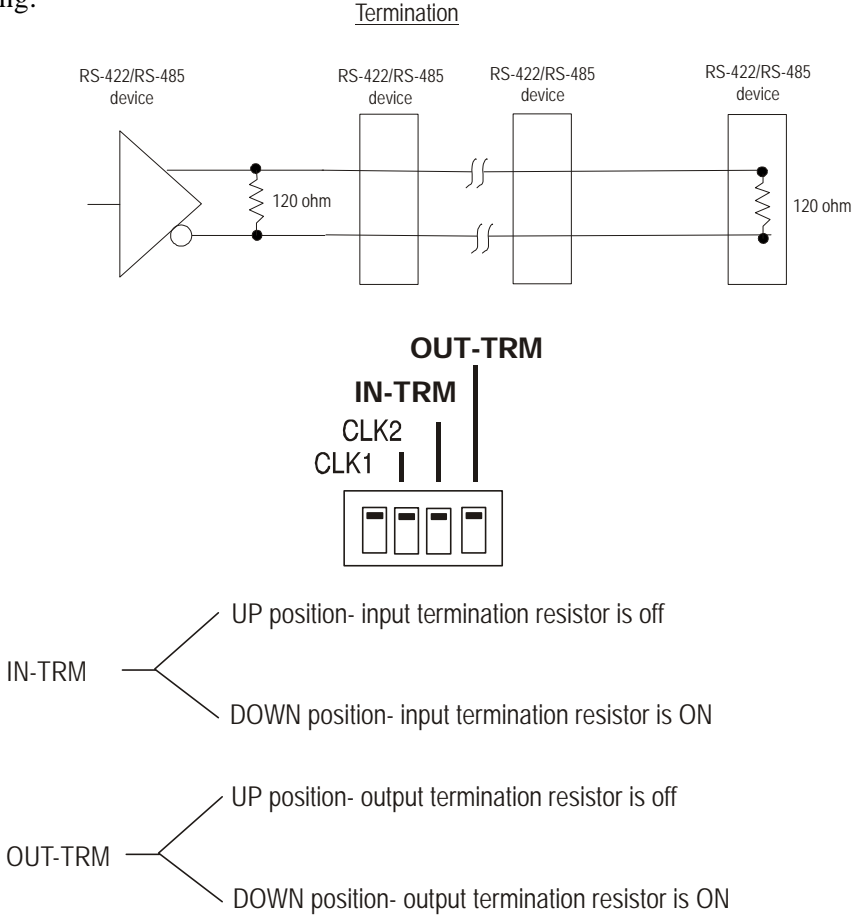

Chapter 2 - Installation

Unpacking the Unit

Before unpacking any equipment, inspect all shipping containers for evidence of external damage caused during transportation. The equipment should also be inspected for damage after it is removed from the container(s). Claims concerning shipping damage should be made directly to the pertinent shipping agencies. Any discrepancies should be reported immediately to the TC Communications Inc. Customer Service Department.

Equipment Location

The TC1520 should be located in an area that provides adequate lighting and working space. Avoid locating it next to any equipment that may produce electrical interference or strong magnetic fields, such as elevator shafts, heavy duty power supplies, etc.

Installation Procedure Summary

The TC1520 is designed for quick and easy installation. Follow the diagram on the next page.

Installation Procedure:

- A. Plug in the 12VDC power supply to TC1520, all the LEDs except PWR should flash for three seconds.
- B. Connect the local and remote units with optic cables as shown.
- C. Connect your local user's device. (See installation diagram on last page) Make sure polarity matches. The "TD" LED shows the logic status of input (from user's device). The "RD" LED shows the logic status of output (to user's device).
- D. Connect the optic cable as shown in installation diagram. Observe that the "OPT SYNC" LED should be flashing when no optic signal is received then turn to solid after a valid optic signal is received.
- F. Make sure the DIP switch settings:
for RS-422— CLK1 and CLK2 should be "UP".

for RS-485— CLK1 and CLK2 should be set according to data rate.
(refer to the following table below).

NOTE: After installation is completed, it is an excellent idea to verify and record the optical cable loss. This reading will both verify the integrity of the circuit and provide a benchmark for future troubleshooting efforts.

CLK1	CLK2	
0	0	RS-422 only
1	0	4/2-wire RS-485 for baud rate > 9600bps
0	1	4/2-wire RS-485 for baud rate > 25 kbps
1	1	4/2-wire RS-485 for baud rate > 250 kbps

0 = UP
1 = DOWN

Quick Installation example for 4-wire RS-485

Following diagram is an example for a 4-wire RS-485 application.

The host controller is communication with a remote device 2 through a 4-wire RS-485 bus. The data sent is continuous data stream.

- date rate: 9600Baud async
- electrical interface: 4-wire RS-485
- DIP switches: CLK1 down, CLK2 up.
- LED indicators to observe: on: "PWR" "OPTIC SYNC" "RS-485"
flash(dim): "TD" "RD" "DRV MODE"

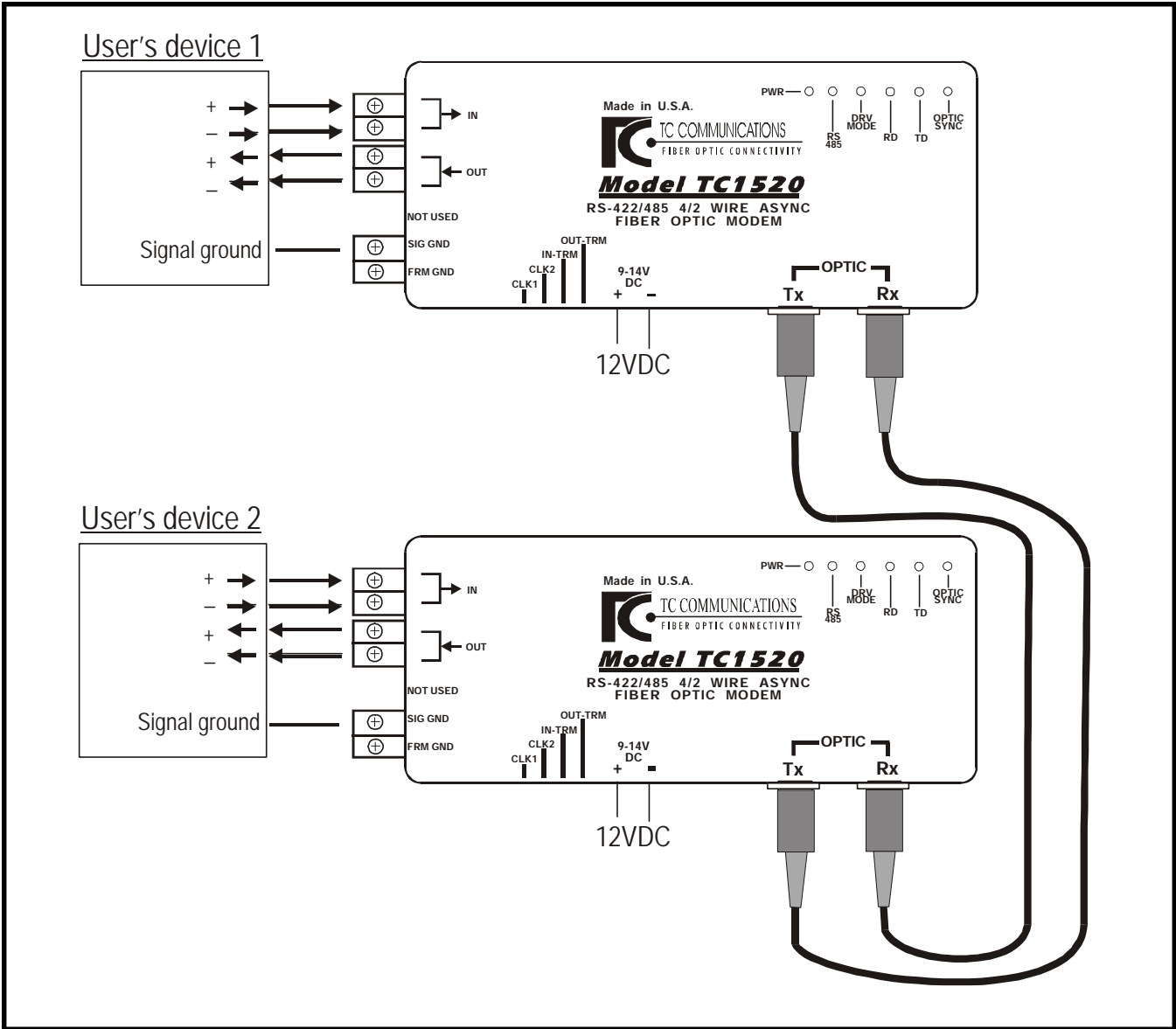

Quick Installation example for 2-wire RS-485

Following diagram is an example for a 2-wire RS-485 application.

The SCADA host computer is polling the status of a remote RTU through a 2-wire RS-485 bus. Once the remote RTU receives a polling command, it answers with a response signal. The communication is half-duplex, the polling device and responding device take turns to transmitting.

date rate: 9600Baud async

electrical interface: 2-wire RS-485

DIP switches: CLK1 down, CLK2 up.

LED indicators to observe: on: "PWR" "OPTIC SYNC" "RS-485"
flash(dim): "DRV MODE"
alternate flash: "TD" "RD"

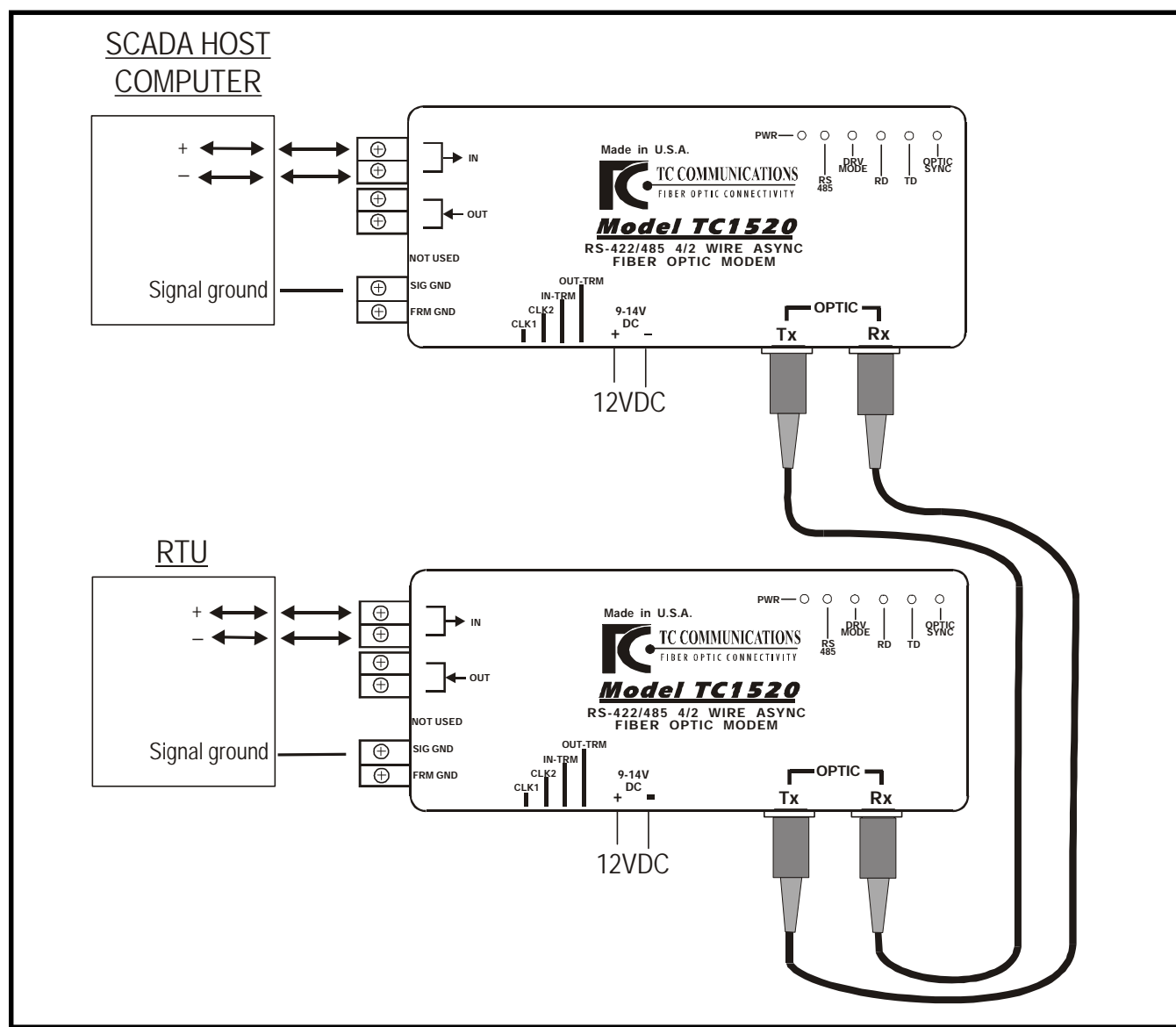

Connect to a BERT Tester with RS-530
for 2-wire RS-485 Testing

2-wire RS-485 Quick Installation
(local & remote Units)



Set Tester to DTE device

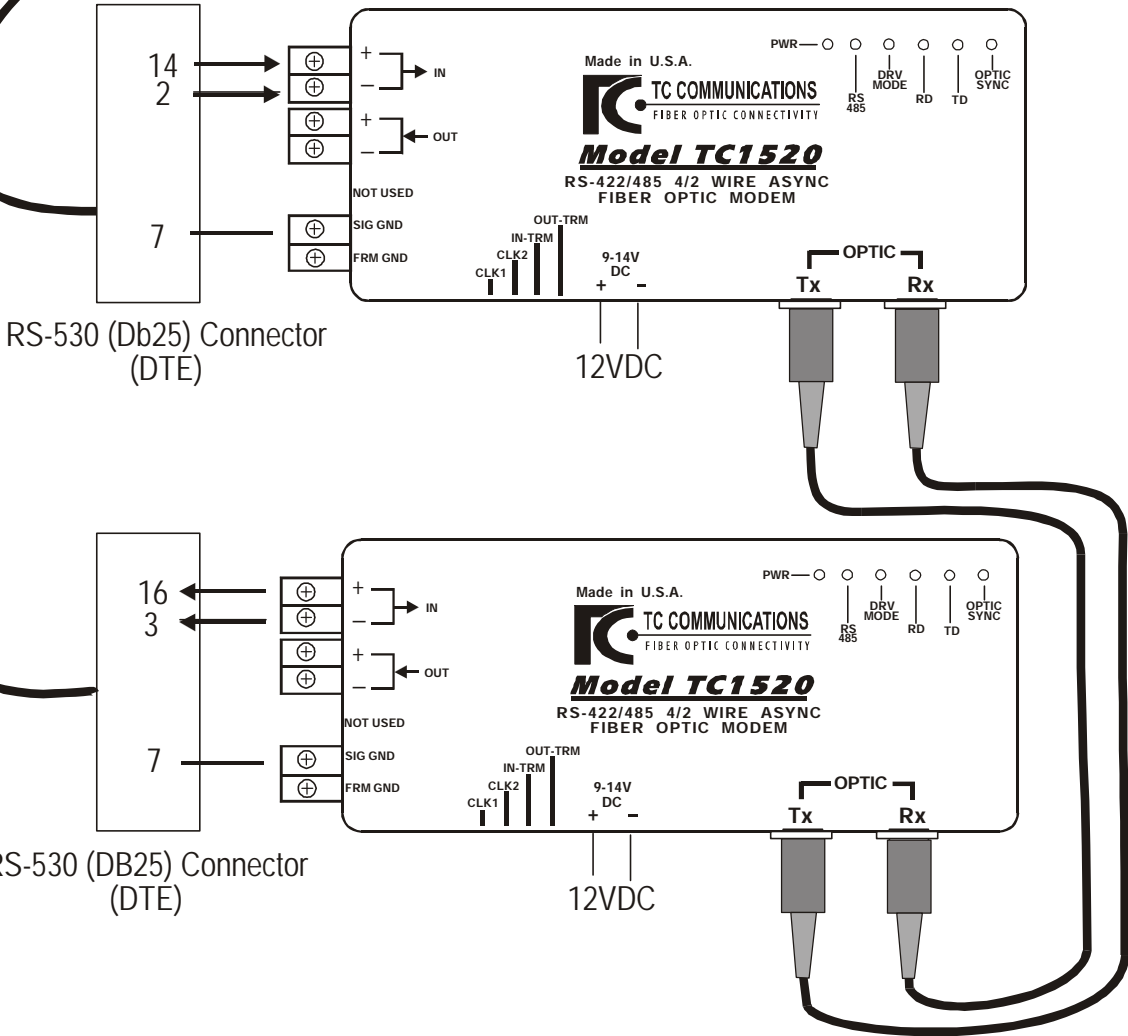

Connect to a BERT Tester with RS-449
for 2-wire RS-485 Testing

2-wire RS-485 Quick Installation
(local & remote Units)

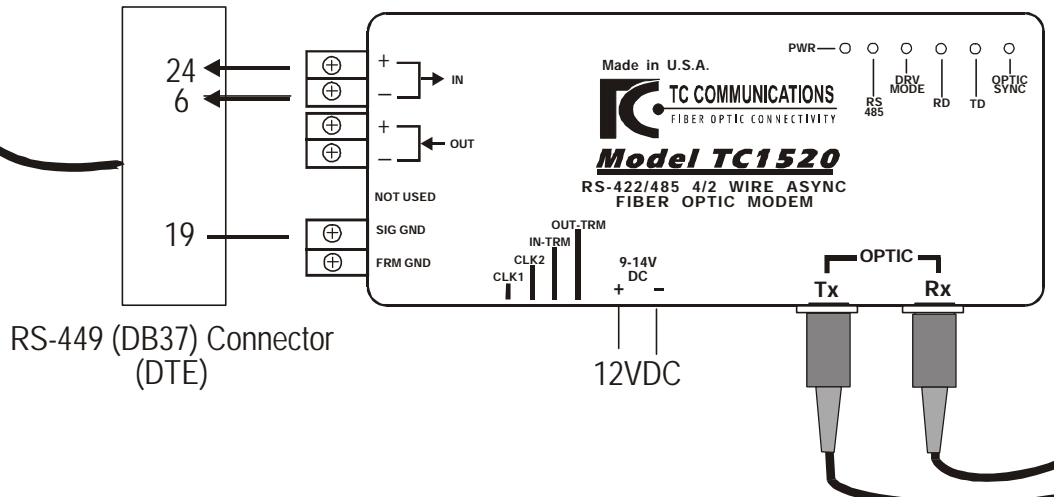
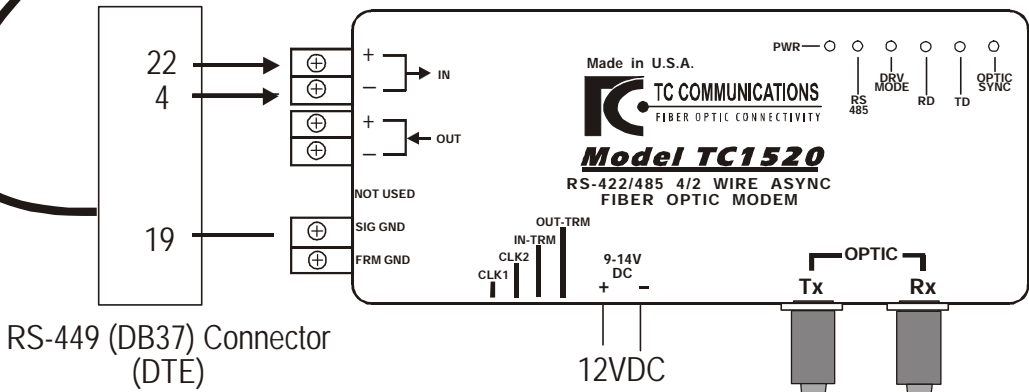
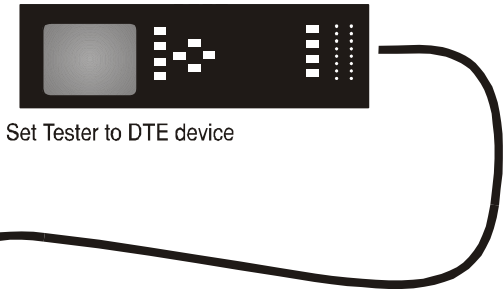

Chapter 3 - Specifications

Data Rates

Async up to 500kbps

Optical

Transmitter LED/ELED

Receiver PIN

Wavelength 850nm/1300nm multimode

..... 1300nm/1550nm single mode

Fiber Optic connectors *ST (FC optional)

Loss Budget**

..... 15 dB multimode 850nm/1300nm @62.5µm

..... 20 dB single mode 1300nm @9µm

Electrical

Connector Terminal Blocks

Interface RS-422 or 4/2-wire RS-485

* ST is a trademark of AT&T ** check factory for laser version

System

Bit error rate 1 in 10⁹ or better

Visual indicator OPT SYNC, TxD, RxD, DRV MODE, RS-485, PWR

Alarm Alarm, OPT-A, OPT-B

Power

Power source 12VDC@200mA

Optional 24VDC@100mA

Optional 115 or 230VAC with external power cube

Temperature

Operating -10⁰C to 50⁰C

Hi-Temp(Optional) -20⁰C to 70⁰C

Storage -40⁰C to 90⁰C

Humidity 95% non-condensing

Physical

Height (1.91 cm) 0.75"

Width (10.16 cm) 4.0"

Depth (6.10 cm) 2.4"

Weight (275 gm) 7oz

Appendix A

Return Policy

To return a product, you must first obtain a Return Material Authorization number from the Customer Service Department. If the product's warranty has expired, you will need to provide a purchase order to authorize the repair. When returning a product for a suspected failure, please provide a description of the problem and any results of diagnostic tests that have been conducted.

Warranty

Damages by lightning or power surges are not covered under this warranty.

All products manufactured by TC Communications, Inc. come with a five year (beginning 1-1-02) warranty. TC Communications, Inc. warrants to the Buyer that all goods sold will perform in accordance with the applicable data sheets, drawings or written specifications. It also warrants that, at the time of sale, the goods will be free from defects in material or workmanship. This warranty shall apply for a period of five years from the date of shipment, unless goods have been subject to misuse, neglect, altered or destroyed serial number labels, accidents (damages caused in whole or in part to accident, lightning, power surge, floods, fires, earthquakes, natural disasters, or Acts of God.), improper installation or maintenance, or alteration or repair by anyone other than Seller or its authorized representative.

Buyer should notify TC Communications, Inc. promptly in writing of any claim based upon warranty, and TC Communications, Inc., at its option, may first inspect such goods at the premises of the Buyer, or may give written authorization to Buyer to return the goods to TC Communications, Inc., transportation charges prepaid, for examination by TC Communications, Inc. Buyer shall bear the risk of loss until all goods authorized to be returned are delivered to TC Communications, Inc. TC Communications, Inc. shall not be liable for any inspection, packing or labor costs in connection with the return of goods.

In the event that TC Communications, Inc. breaches its obligation of warranty, the sole and exclusive remedy of the Buyer is limited to replacement, repair or credit of the purchase price, at TC Communications, Inc.'s option.

To return a product, you must first obtain a Return Material Authorization (RMA) number and RMA form from the Customer Service Department. If the product's warranty has expired, you will need to provide a purchase order to authorize the repair. When returning a product for a suspected failure, please fill out RMA form provided with a description of the problem(s) and any results of diagnostic tests that have been conducted. The shipping expense to TC Communications should be prepaid. The product should be properly packaged and insured. After the product is repaired, TC Communications will ship the product back to the shipper at TC's cost to U.S. domestic destinations. (Foreign customers are responsible for all shipping costs, duties and taxes [both ways]. We will reject any packages with airway bill indicating TC communications is responsible for Duties and Taxes. To avoid Customs Duties and Taxes, please include proper documents indicating the product(s) are returned for repair/retest).